

A new approach to on-line monitoring of biofilm and scales in cooling systems

PhD. Gaëlle Guillemot

MEMS sensors for real-time & in-situ water-quality monitoring

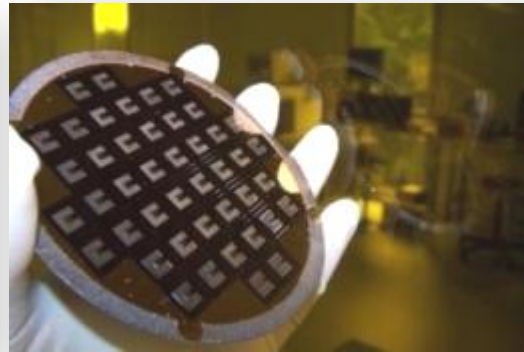
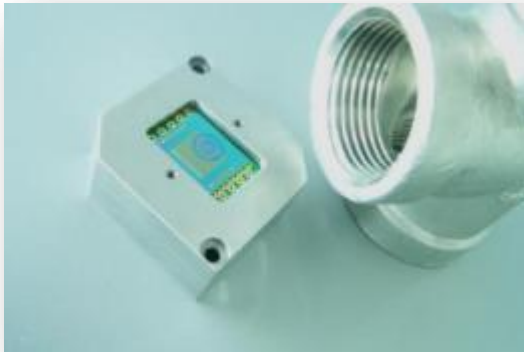

Developing continuous & real-time liquid quality monitoring & control solutions based on MEMS technologies to optimize industrial processes, to protect our environment and to extend life of equipment



- Founded in 2001
- Based in Toulouse, France





**ALL industrial processes and water-treatment
are concerned by FOULING**



- ✓ Sanitary safety
- ✓ Quality of products
- ✓ Industrial efficiency and competitiveness
- ✓ Increase of process uptime
- ✓ Reduction of energy consumption
- ✓ Waste reduction
- ✓ ...

**Needs of new
tools & solutions
for alerting &
preventing**

“You can’t improve what you can’t measure...”

NEOSENS brings up THE new sensor generation
for online, continuous, & in-situ liquids quality monitoring

Neosens™ FS-900 Series





Patent FR2885694 A1
Patent WO2007/003801 A2



- Measurement range : 10µm...10mm
- Different geometries
- Resistant to harsh environments
- High-temperature compatible and hygienic
- Operational in all liquids

- Tactile graphical display
- Industrial grade (IP65)
- 8 x 4-20mA outputs
- Metal box enclosure
- Modem option

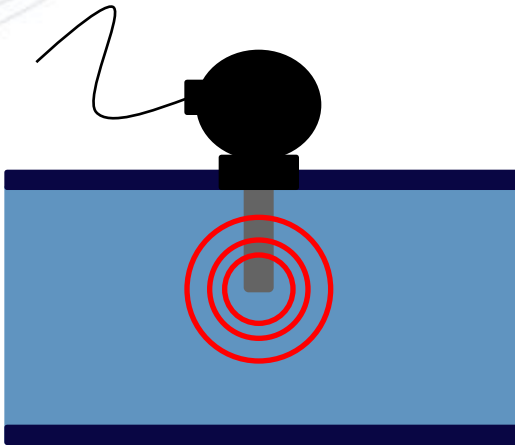

NO-FOULING STATE

- Sensor acts as a reverse micro-thermal exchanger
- Thermal diffusion to medium (liquids) is 100% efficient

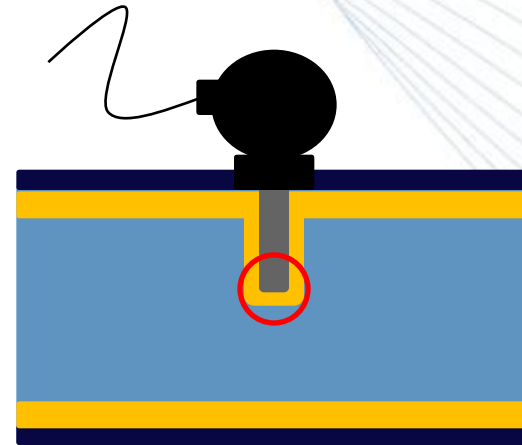

FOULING STATE

- Thermal drift is recorded by the probe, « intensity » is linked to thickness of deposit
- Sensor works with a patented Thermal Pulse Analysis method

Examples of industrial setups

FOOD



COOLING



PAPER



FOOD INDUSTRY (DAIRY)



Purpose

- To better monitor on-line & in-situ fouling (compared to global methods)
- To confirm CIP efficiency (real-time monitoring)
- To monitor global process at many points and in many conditions (from evaporators to packaging)



Field results from industrial site (milk)

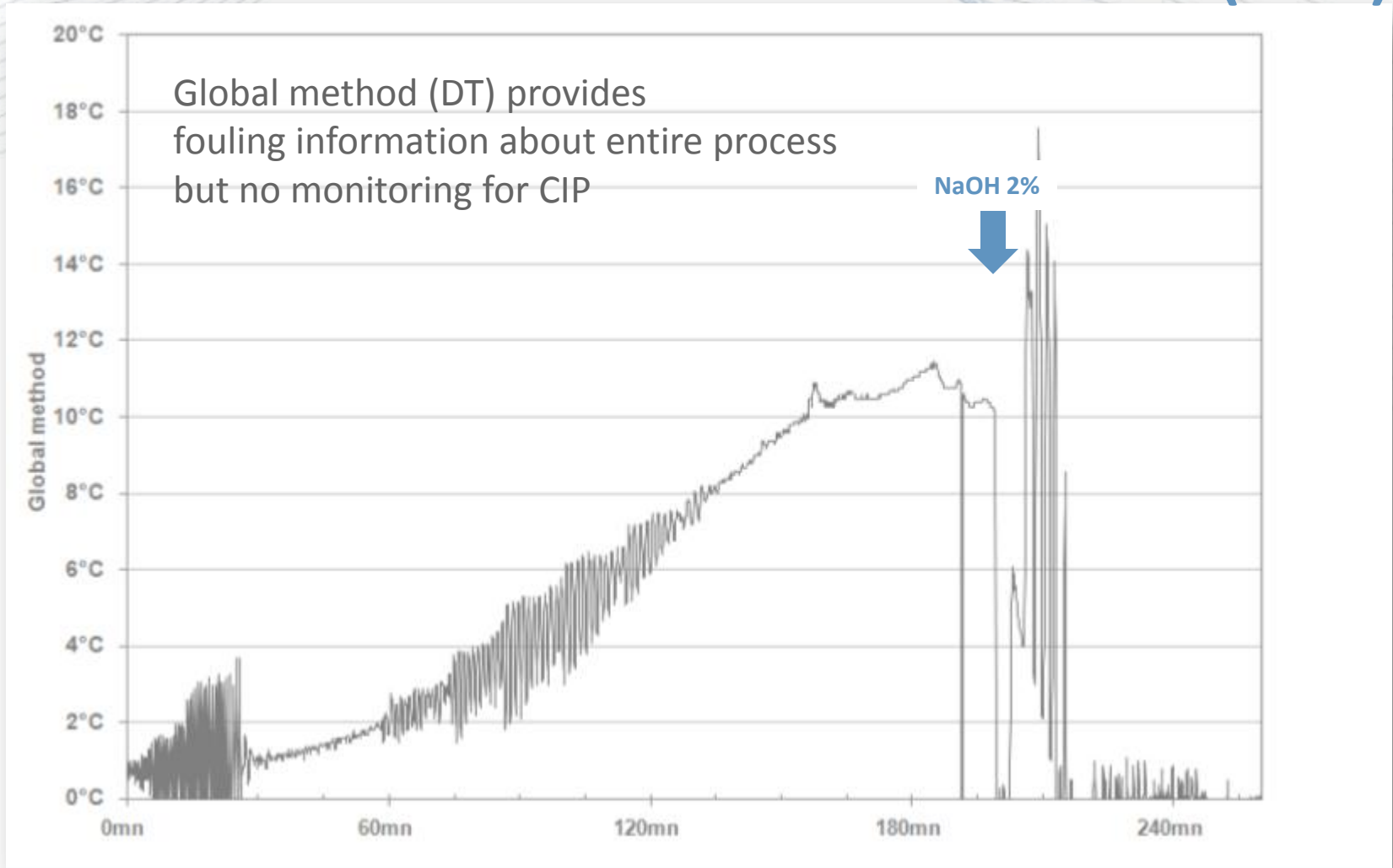

Field results from industrial site (milk)

Our technology provides :

1. Local information of fouling *versus* time,
2. CIP checking efficiency (real-time)

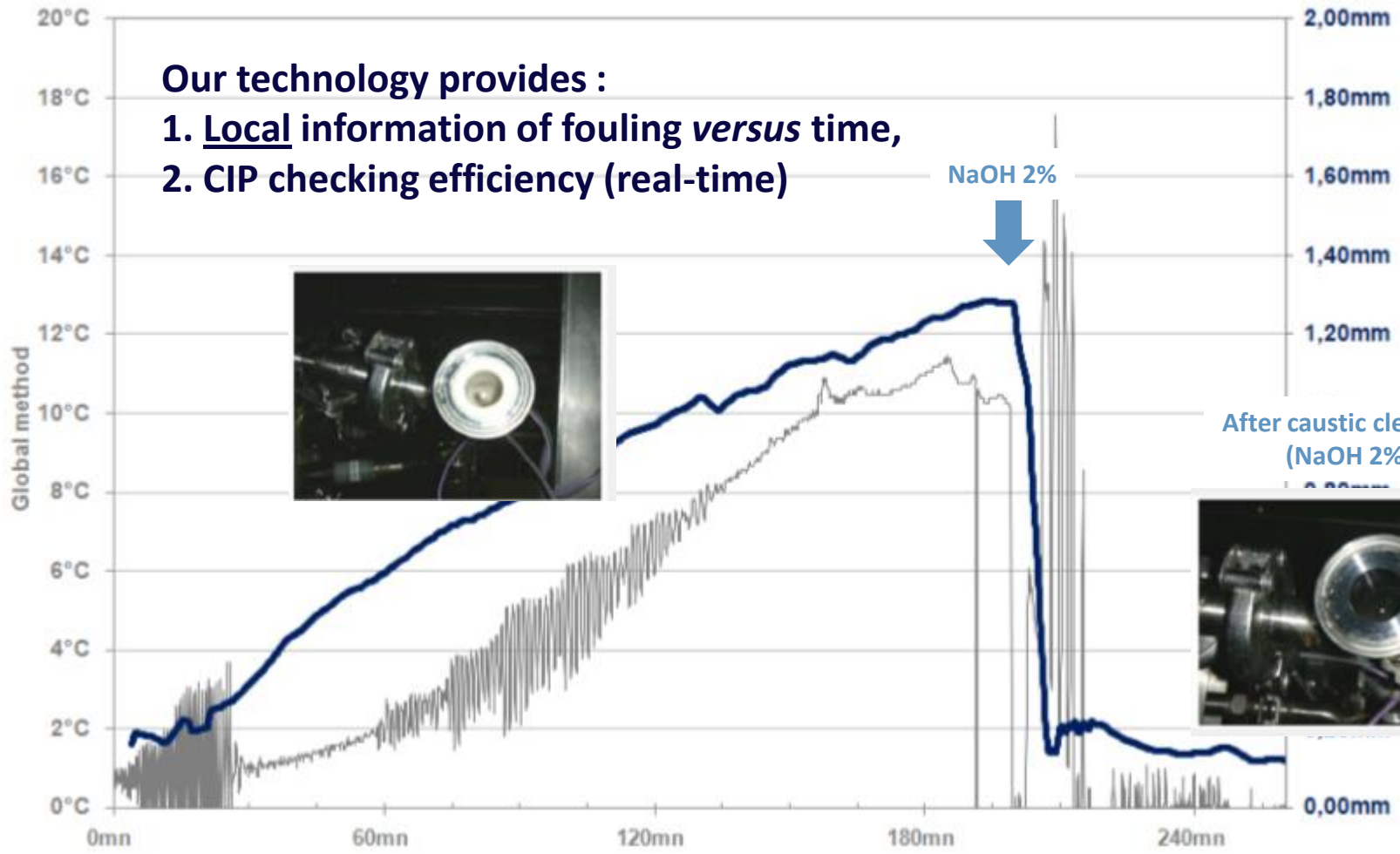

ROI approach for CIP “checking-tool” concept

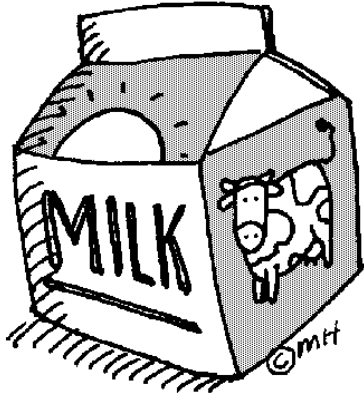

Production 400.000 L/day
~0,45\$/L
180 000\$/day

Product safety is assessed and take 3 days !

If contaminated,

Losses = 3 days x



= 540 000 \$!!!

Production 400.000 L/day
~0,45\$/L
180 000\$/day

If only **1 biocontamination is avoided per year**, thanks to CIP real-time checking, then costs-savings (reduction of production loss) are **540k\$** at least !!



Purpose

- To monitor on-line & in-situ heat exchange effectiveness
- To assess *Legionella* risk
- To optimize chemicals consumption & discharge (biocides and anti-scale)

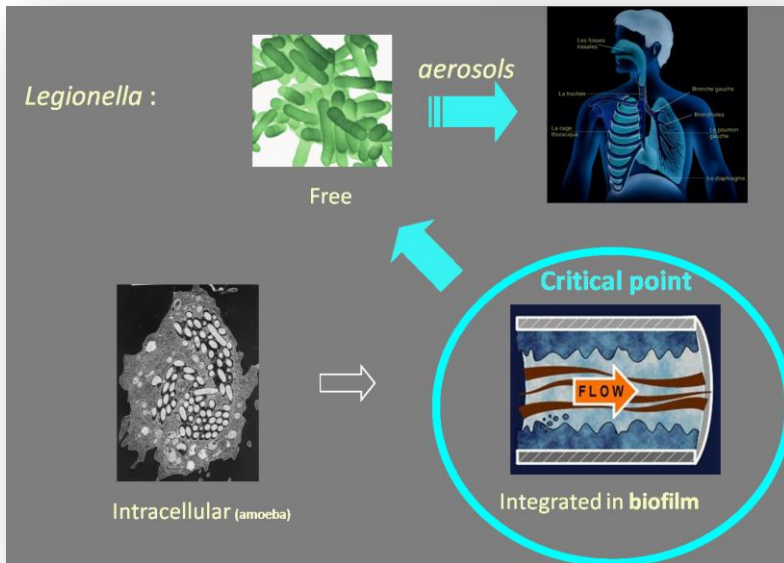

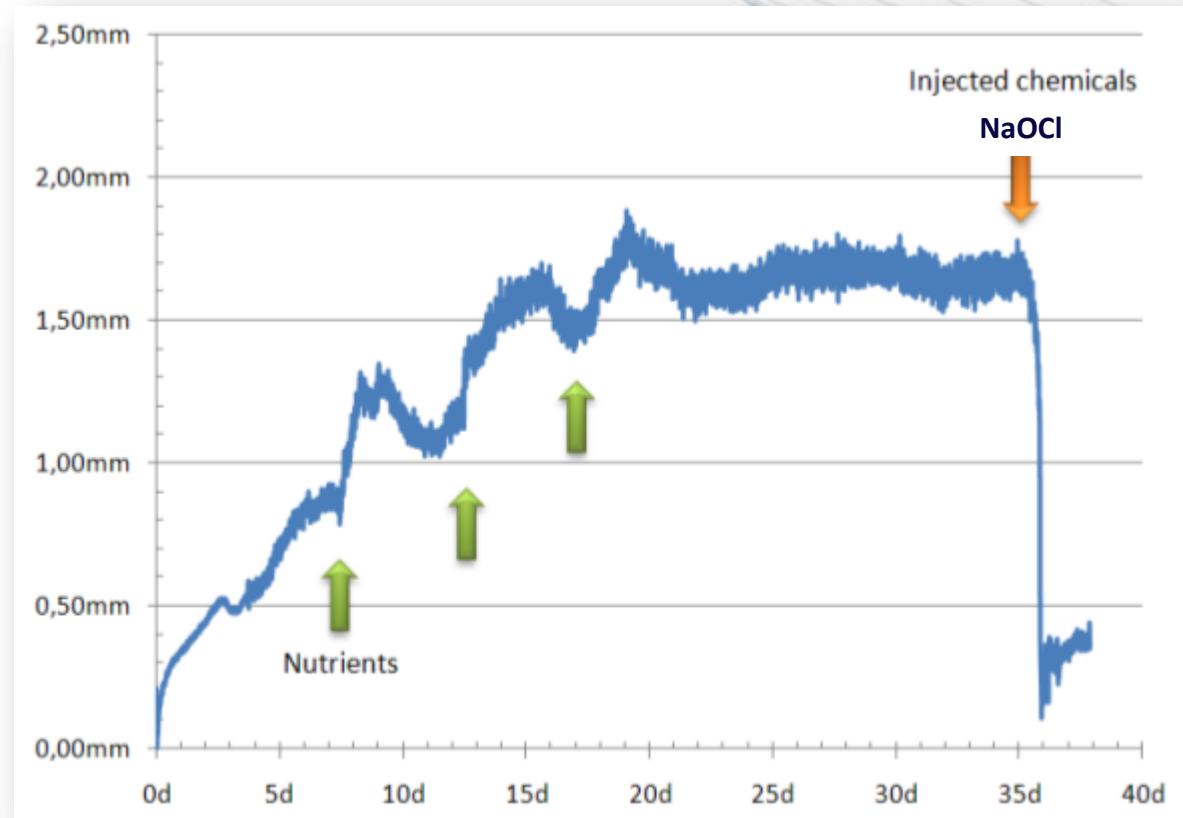

Implanted in a monitoring pilot for detection of biofilm, scale and corrosion in cooling systems of oil refinery



- ✓ 520L
- ✓ Potable water, pH=8
- ✓ 166 kW (T : 38 & 32 C)
- ✓ 12 m³/h
- ✓ Fan is off

Tableau 2 : Paramètres physico chimiques de l'eau

Paramètres	minimum	maximum	moyenne	médiane
Conductivité $\mu\text{S}/\text{cm}^2$	528,90	1821,00	996,29	1014,00
Facteur Concentration	0,00	3,40	1,85	1,89
Turbidité NTU	0,00	14,00	4,41	3,00
TA (°f)	0,00	11,10	4,54	3,70
TAC (°f)	17,20	58,00	40,27	39,75
TH (°f)	26,70	88,90	53,25	50,30
Fer (mg/l)	0,01	8,98	0,85	0,43
Zinc (mg/l)	0,01	4,04	0,85	0,66
MES (mg/l)	2,00	40,00	8,57	5,00

Under treatment **NO TREATMENT !**

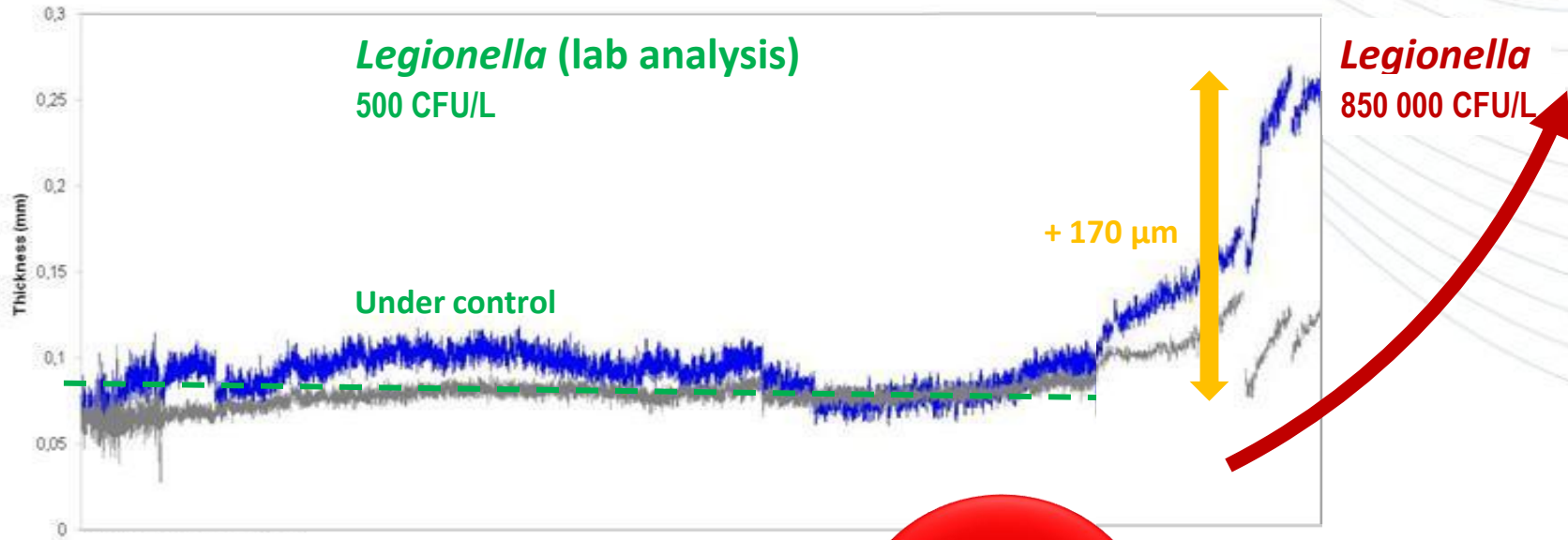

8 months monitoring of biofilm



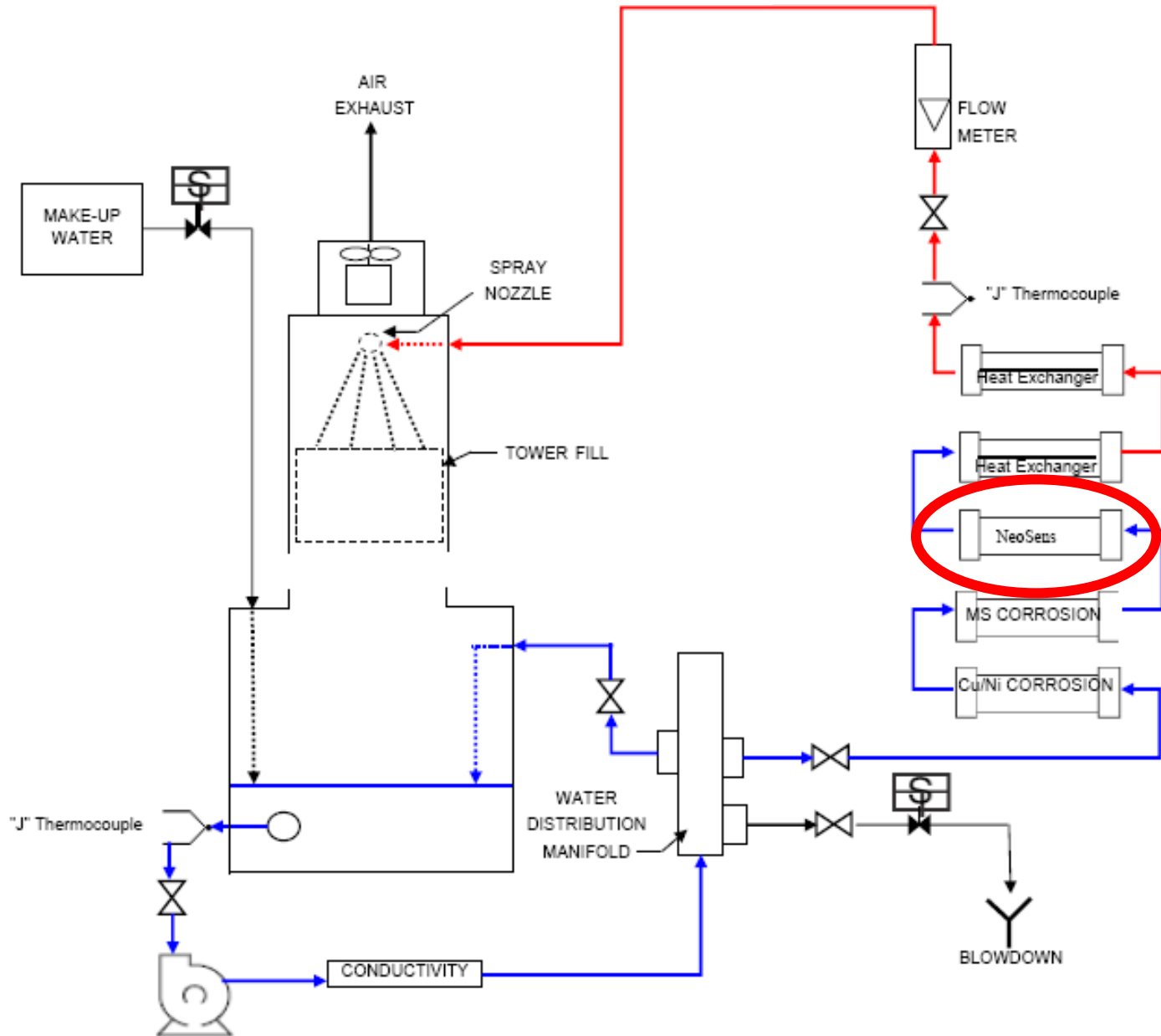

Phigenics PCT Setup				NeoSens Test 1				NeoSens Test 2				NeoSens Test 3			
NeoSens Evaluation				LSI: 2.50				Setup Parameters							
Enter Data PCT 1				Enter Data PCT 2				Enter Data PCT 3							
Basic Parameters:				PCT 1 - NeoSens FS Probe 1				PCT 2 - NeoSens FS Probe 2				PCT 3 - NeoSens FS Probe 3			
Tower Recirculation (GPM)	R	2.8	GPM	2.8	GPM	2.8	GPM	2.8	GPM	2.8	GPM	2.8	GPM	2.8	GPM
Flow Rates==>		Heat Exchangers		NeoSens		Heat Exchangers		NeoSens		Heat Exchangers		NeoSens		Heat Exchangers	
		FPS	GPM	FPS	GPM	FPS	GPM	FPS	GPM	FPS	GPM	FPS	GPM	FPS	GPM
		1.5	2.8	2.0	4.9	1.5	2.8	2.0	4.9	1.5	2.8	2.0	4.9	1.5	2.8
Design Temperature	delta T	3.4	Degrees F	3.4	Degrees F	3.4	Degrees F	3.4	Degrees F	3.4	Degrees F	3.4	Degrees F	3.4	Degrees F
Cycles of concentration	C	4.0	(specify value)	4.0	(specify value)	4.0	(specify value)	4.0	(specify value)	4.0	(specify value)	4.0	(specify value)	4.0	(specify value)
Drift Losses (%)	D	0.001%	(enter 0.001% as 0.00001)	0.001%	(enter 0.001% as 0.00001)	0.001%	(enter 0.001% as 0.00001)	0.001%	(enter 0.001% as 0.00001)	0.001%	(enter 0.001% as 0.00001)	0.001%	(enter 0.001% as 0.00001)	0.001%	(enter 0.001% as 0.00001)
Leakage Losses (%)	L	0.0001%		0.0001%		0.0001%		0.0001%		0.0001%		0.0001%		0.0001%	
System Volume	V	5	Gallons	5	Gallons	5	Gallons	5	Gallons	5	Gallons	5	Gallons	5	Gallons
Load Factor (Operating)	LF	85%	(enter 85% as 0.85)	85%	(enter 85% as 0.85)	85%	(enter 85% as 0.85)	85%	(enter 85% as 0.85)	85%	(enter 85% as 0.85)	85%	(enter 85% as 0.85)	85%	(enter 85% as 0.85)
Operating Hours per Day	hpd	24	Hours	24	Hours	24	Hours	24	Hours	24	Hours	24	Hours	24	Hours
Operating Days per Week	dpw	7	Days	7	Days	7	Days	7	Days	7	Days	7	Days	7	Days
Operating Weeks per Year	wpy	52	Weeks	52	Weeks	52	Weeks	52	Weeks	52	Weeks	52	Weeks	52	Weeks
Derived Heat Load	Q	4,688	btu/hr	# Heat Ex Rqd: 3	4,688	btu/hr	# Heat Ex Rqd: 3	4,688	btu/hr	# Heat Ex Rqd: 3	4,688	btu/hr	# Heat Ex Rqd: 3	4,688	btu/hr
Heat Exc Name	Watts	Heater Area (ft²)	Pos	Heat Load	Heat Flux	Volts	Variac %	Heat Load	Heat Flux	Volts	Variac %	Heat Load	Heat Flux	Volts	Variac %
316 SS (Exc 5)	1150	0.12963	Exc #5	2,204	17,000	67	56	2,204	17,000	67	56	2,204	17,000	67	56
316 SS (Exc 4)	1150	0.12963	Exc #4	3,111	24,000	95	79	3,111	24,000	95	79	3,111	24,000	95	79
Cooling Tower Calculations															
		Gal/min	Gal/day	mi/min	mi/day	Gal/min	Gal/day	mi/min	mi/day	Gal/min	Gal/day	mi/min	mi/day	Gal/min	Gal/day
Evaporation Rate	E	0.00796	11.460	30.13	43,381.7	0.00796	11.460	30.13	43,381.7	0.00796	11.460	30.13	43,381.7	0.00796	11.460
Makeup Water Rate	M	0.01061	15.280	40.17	57,842.2	0.01061	15.280	40.17	57,842.2	0.01061	15.280	40.17	57,842.2	0.01061	15.280
Bleed Rate	B	0.00262	3.776	9.93	14,295.4	0.00262	3.776	9.93	14,295.4	0.00262	3.776	9.93	14,295.4	0.00262	3.776
Drift Loss estimate	D	0.00003	0.040	0.10	150.1	0.00003	0.040	0.10	150.1	0.00003	0.040	0.10	150.1	0.00003	0.040
Leakage Loss estimate	L	0.00000	0.004	0.01	15.0	0.00000	0.004	0.01	15.0	0.00000	0.004	0.01	15.0	0.00000	0.004
Timed Based Operating Parameters															
		Minutes	Hours	Days	Minutes	Hours	Days	Minutes	Hours	Days	Minutes	Hours	Days	Minutes	Hours
Holding Time Index (HTI)		1,321.5	22.0	0.9	1,321.5	22.0	0.9	1,321.5	22.0	0.9	1,321.5	22.0	0.9	1,321.5	22.0
Retention Time		1,906.6	31.8	1.3	1,906.6	31.8	1.3	1,906.6	31.8	1.3	1,906.6	31.8	1.3	1,906.6	31.8
Time per Cycle		1.8	0.03	0.0	1.8	0.03	0.0	1.8	0.03	0.0	1.8	0.03	0.0	1.8	0.03

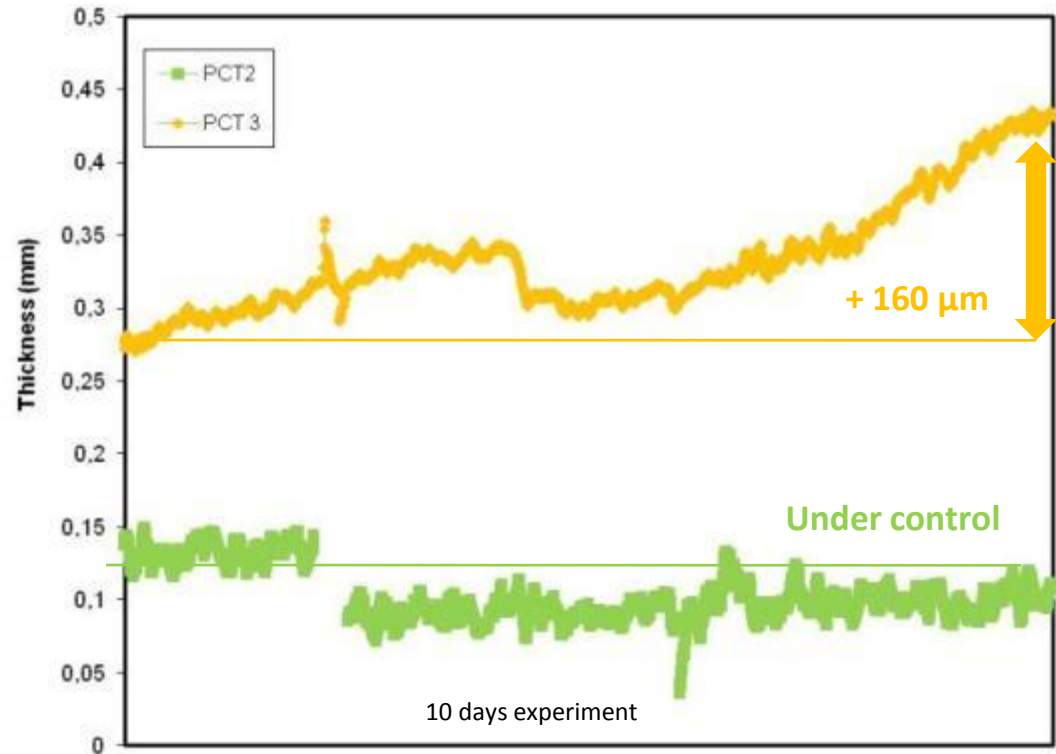

1st run : July 2008
2nd run : Now !!!



Benefits of the FS-900 system

- ✓ **Unique** system to measure on-line, in real-time and continuously **fouling phenomenon**
- ✓ Rugged technology
- ✓ Easy to install, setup and operate
- ✓ Limited maintenance

Transposition to MEMS Technology

Collective process, quality & reliability of components



	FS-900	μ FS
Measurement range T (C)	0 - 150 C	0 - 150 C
Precision (C)	0,2 - 0,3 C	<0,1 C
Response time (s)	20s (90%)	1s
Power	~100mW	<50mW
Thickness measurement range	~10 μ m - ~10mm	1 μ m - mm
Surface	100mm ²	10mm ²
Flow-rate	>5 L/min	~0

Thank you

Biofilm – Scales – Monitoring – Anticipation – Control – Alert – Optimization –
Environment – Industry – Fouling – Dissolved Oxygen – MEMS – innovation – Know-how
– Solutions – Sensors – water – liquids – Process – Industry

www.neo-sens.com

